

DATA SHEET

8" Prime Evo EC | 147653

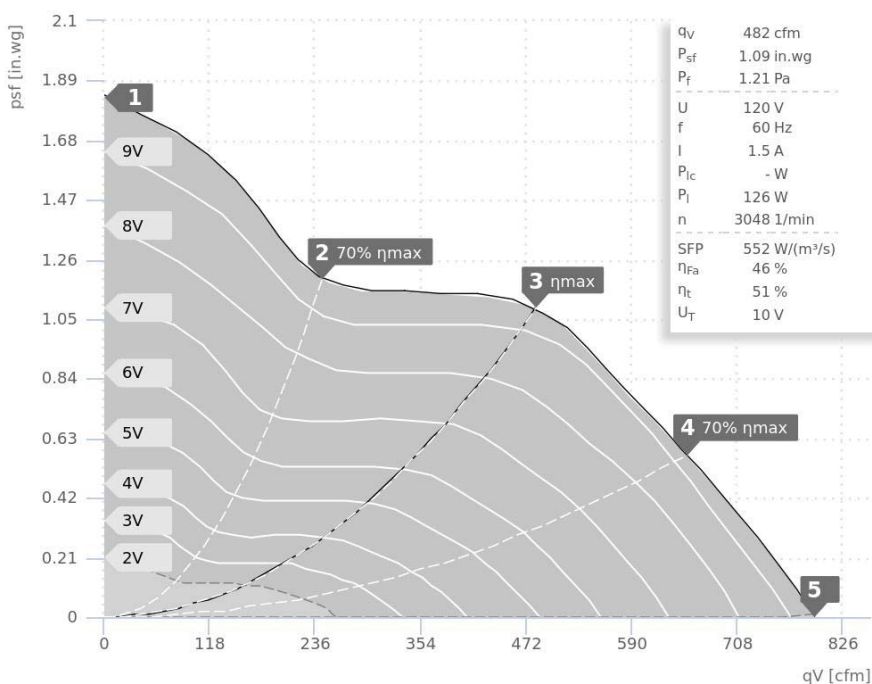

Operating Point		1	2	3	4	5
Current I	A	1,4	1,2	1,5	1,5	1,5
Power consumption P _i	W	113	99	126	127	122
RPM n	1/min	3134	3145	3047	2944	2995
SPL inlet L _{WA5}	dB(A)	78	76	76	76	77
SPL outlet L _{WA6}	dB(A)	79	77	80	78	79
SPL casing break out L _{WA2}	dB(A)	59	59	57	57	58

Sound power (L _W) dB(A)		Medium Frequency Band								
		Σ	63	125	250	500	1k	2k	4k	8k
Inlet	L _{WA5}	76	43	56	66	72	70	67	61	54
Outlet	L _{WA6}	80	40	59	68	73	76	72	68	59
Casing	L _{WA2}	57	44	44	47	47	51	53	45	37

8" Prime Evo EC 147653	
Voltage U _N	120 V 1~
Current I _{max}	1,6 A
Ambient temperature t _A	50 °C
Medium temperatures t _M	50 °C
Speed Control	0-10V
Motor protection	TEC
Insulation class motor	F
Weight	4,0 kg
Poles	-
IP motor	IP54
IP terminal box	IP44
Min. operating temperature	-30 °C

Ruck Air Movement - Master Series by



2082 58th Ave. Circle E.
Bradenton, FL 34203

Phone: 941.739.0879

Fax: 941.739.0881

www.mastervent.com marion.pye@mastervent.com

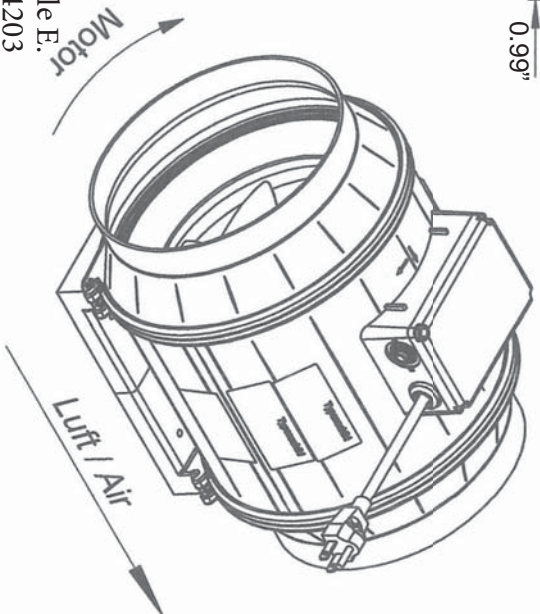
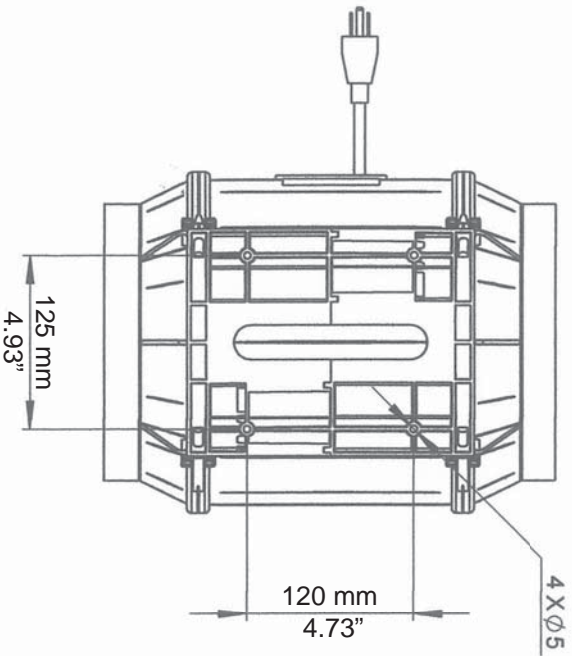
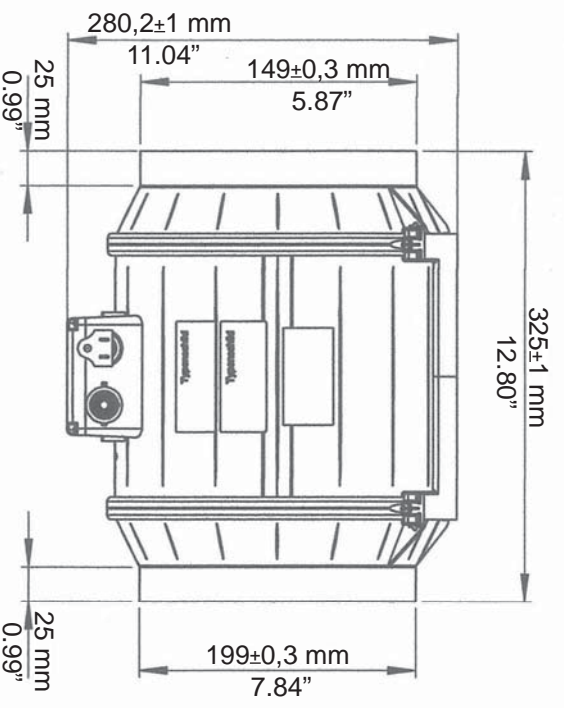
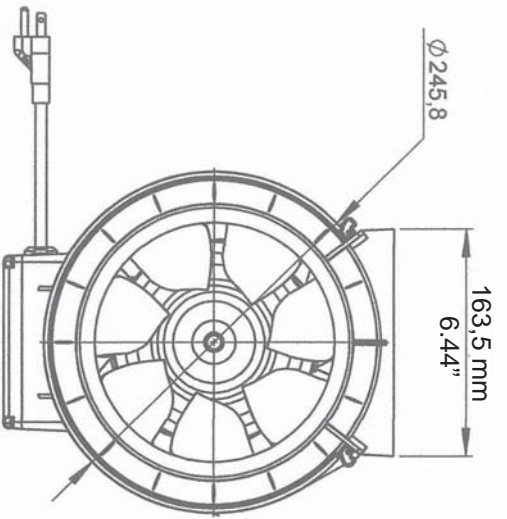

2082 58th Ave. Circle E.
Bradenton, FL 34203
Phone: 941.739.0879
Fax: 941.739.0881
www.mastervent.com
marion.pye@mastervent.com

8" Prime EVO EC 147653

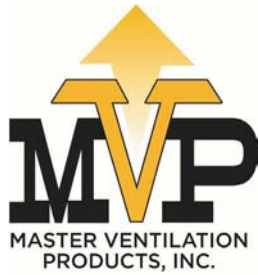

SUBMITTAL DATA and SPECIFICATIONS for MVP/RAM SERIES

SERIES: Mixed Flow

Prime EVO EC Models

Application: Inline Mixed Flow Fans/ Blowers designed to supply/exhaust applications for Residential, Commercial, Light Industrial and OEM market.

Manufacturer: Ruck (EU)

Material of Construction: All models shall be constructed of corrosion resistant plastic for Housing and Mixed Flow Impeller.

Impeller: Impeller shall be constructed of corrosion resistant plastic. Impeller shall be Computer precision designed and will have plastic protection where attached to Motor Shaft.

Material Temperature Limitations: Shall be from 40C/104F to 60C/140F Ambient to 40C/104F to 40C/104F Medium for Models as specified.

Motors: Shall be energy efficient EC Motors and Speed Controllable with 0 to 10V DC Signals. Motors shall be 120V/1/60 AC input for Models 6” Prime EVO EC through 14” Prime EVO EC or 240V /1/60 AC input for Models 14” Prime EVO EC HO and 16” Prime EVO EC as specified. Motors shall be rated Continuous Duty with sealed for life Maintenance Free Ball Bearings. Motors shall be Thermally Protected. Motor Shall be in the Airstream for efficient heat dissipation and will be encased in Housing Material of Construction.

Mounting Bracket: Shall be included as Standard and integral with all models.

Safety Certifications: All fans shall conform to ANSI/UL 507 Standard and Certified to Canada Standard C22.2 NO. 113. Intertek 5030171. Fans shall bear the C ETL US Label.

Performance and Sound Certification: Shall be certified to ISO 5801 Standards.

PROJECT				ARCHITECT				
CONTRACTOR		DATE	SUBMITTED BY		ENGINEER			
SPECIFICATION								
Fan Position	Model #	CFM	In. WG	RPM	Watts	Voltage / Phase	Qty	Accessories

WARNING: DO NOT USE IN HAZARDOUS ENVIRONMENTS WHERE FAN’S ELECTRICAL SYSTEM COULD PROVIDE IGNITION TO COMBUSTIBLE OR FLAMMABLE MATERIALS!